

SCHEMATIC: Part No. 7SLIOB16 Smart Base with Memory Mapped I/O

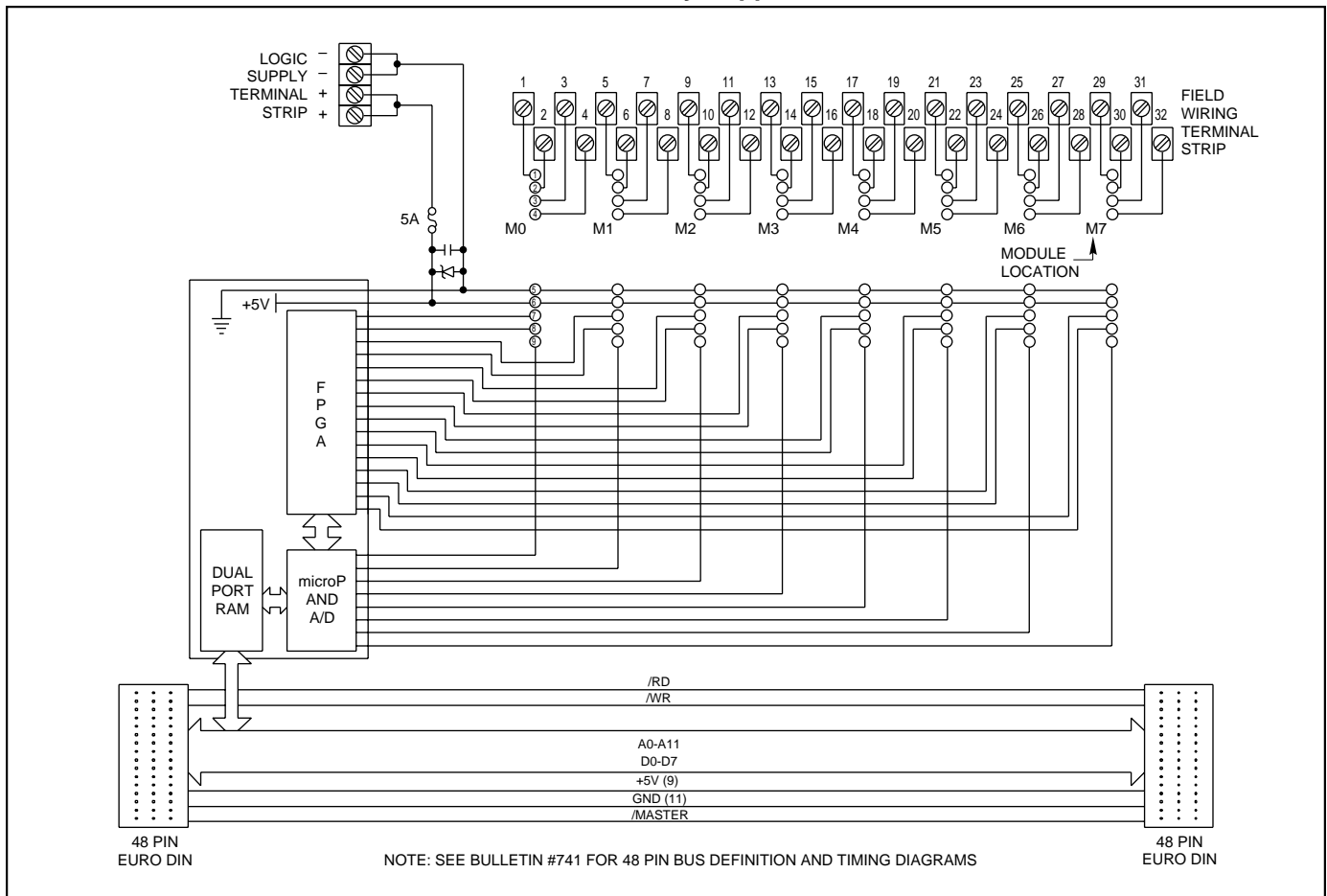

ORDERING INFORMATION (modules ordered separately)

Part Number	I/O	Description	UL	CSA	Style
7SLIOB16	16	Smart bases with dual port RAM interface. 48-pin Euro DIN logic signal connector. DIN rail mount.	X	X	OpenLine®
7SL10B16P	16	Pluggable terminator (w/o plug)	X	X	OpenLine®
7SL10B16WP	16	Pluggable terminator (w/plug)	X	X	OpenLine®
70L-JUMP6	16	Six position jumper bar			OpenLine®

For General Control System Information see pages H-39 to H-42.

ACCESSORIES

See page H-54

Available from your local Grayhill Distributor. For prices and discounts, contact a local Sales Office, an authorized local Distributor or Grayhill.

DIMENSIONS: Jumper Bars

